

ETI MODEL 616004 VARIABLE TRANSFORMER BOX

Instruction Manual

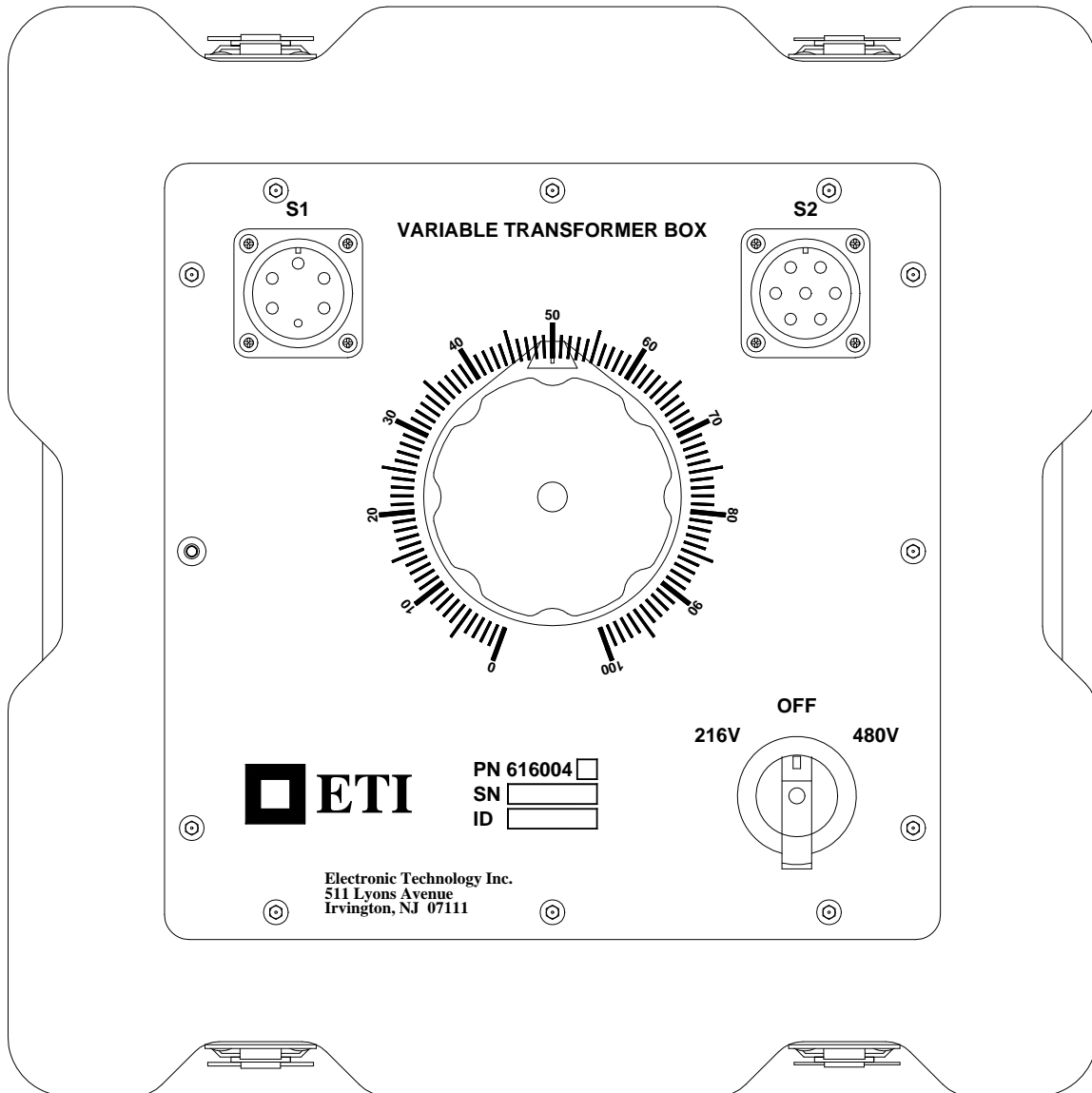

Electronic Technology Incorporated
511 Lyons Avenue, Irvington, NJ 07111
(973) 371-5160 FAX (973) 371-1929
www.eti-nj.com sales@eti-nj.com

REVISIONS

Revision	Date	Details
1	08/10/2004	Initial Revision
2	08/16/2004	Added Figures for WH and GE relays, other minor revisions
3	06/27/2006	Updated for Phase to Phase Input Volts Display
4	07/17/2008	Revised sample test procedure to match IEEE C57.12.44

SAFETY PRECAUTIONS

WARNING

There are potentially dangerous/lethal voltages present during the operation of this test equipment. Failure to follow the instructions in this manual could result in serious injury or death.

The following safety precautions should be followed at all times to prevent personal injury or equipment damage:

1. Always wear proper safety equipment (properly rated gloves, safety glasses, etc) when working with the ETI Automatic Network Protector Test Box.
2. Ensure that all the front panel circuit breakers are all in the off position prior to making any connections to a protector or network bus.
3. No relay is to be either removed or installed while the network protector is energized.
4. **The INPUT VOLTAGE SELECT SWITCH must be in the correct position to match the input voltage. If this switch is set incorrectly equipment damage and/or personal injury may result.**

TABLE OF CONTENTS

Overview.....	1
Setup/Connections	3
Sample Operating Procedures.....	7
Specification Sheet.....	9

Chapter 1

Overview

I. SCOPE

This specification describes the operation of the ETI Variable Transformer Box Model 616004 (henceforth referred to as the “Variac Box”) and its use with the ETI Automatic Network Protector Relay Test Box Model 616001 (henceforth referred to as the “Test Box”).

II. ABOUT THIS DOCUMENT

The various fonts used throughout this document have the following meanings:

- A. Items that are printed on the front panel of the Test Box are shown in boldface italics, for example ***TRIP ALL***.
- B. Text that appears on the Test Box’s display is printed in typewriter font and enclosed in quotes. For example “**Enter Selection: __**”.
- C. Controls, such as buttons and breakers are shown in boldface, for example **CANCEL**.
- D. A button sequence used to select a particular function are shown in boldface between angle brackets, for example **<B,5>**.
- E. All voltages given in this manual are measured Line to Neutral unless otherwise specified.

III. GENERAL

- A. The Variac Box is used to perform various electro-mechanical tests on a network protector, such as Tripping Voltage Range, Trip-Free Voltage, Closing Voltage Range, Motor Control Pick-up, and Low Voltage Motor Close.
- B. The Variac Box can be used in all locations on both 216 and 480 volt network protectors. The input voltage switch on the front panel of the Variac Box **MUST** be set to the input voltage which is supplied on port *SI*.

IV. SUPPLIED EQUIPMENT

The following accessories are included with the Variac Box:

- A. A copy of this manual
- B. A cable to connect to the ETI 616001 Test Box
- C. A Green/Yellow grounding cable
- D. Jumper wire for actuating the trip and close circuits of the network protector

V. DESCRIPTION OF THE VARIAC BOX

- A. The Variac Box is a portable unit provided with a removable cover in which associated cables are stored. Figure 1 shows the main panel and the location of the various controls and operating parts.
- B. The following controls are referred to throughout this manual and are listed below in order to acquaint the operator of the Variac Box with their location and function.
 1. The adjust knob is located on the center of the panel. This control is used to vary the 3 phase voltage supplied to the Test Box and thus the network protector.
 2. The **INPUT VOLTAGE SELECT SWITCH** is located on the lower right corner of the panel. There are three switch positions: *216V*, *OFF*, and *480V*. You must chose the appropriate setting for the input voltage.

- a. If the input voltage is 125/216V set the switch to **216V**. This will give you an adjustable voltage range of 0-300V line to neutral.

Note: In this mode, it is possible to step up the input voltage above 125V. Do not turn the Variac knob past 125V when testing a low voltage protector.

- b. If the input voltage is 277/480V set the switch to **480V**. This will give you an adjustable voltage range of 0-277V line to neutral.

Note: Failure to set this switch correctly can result in equipment damage and/or personal injury

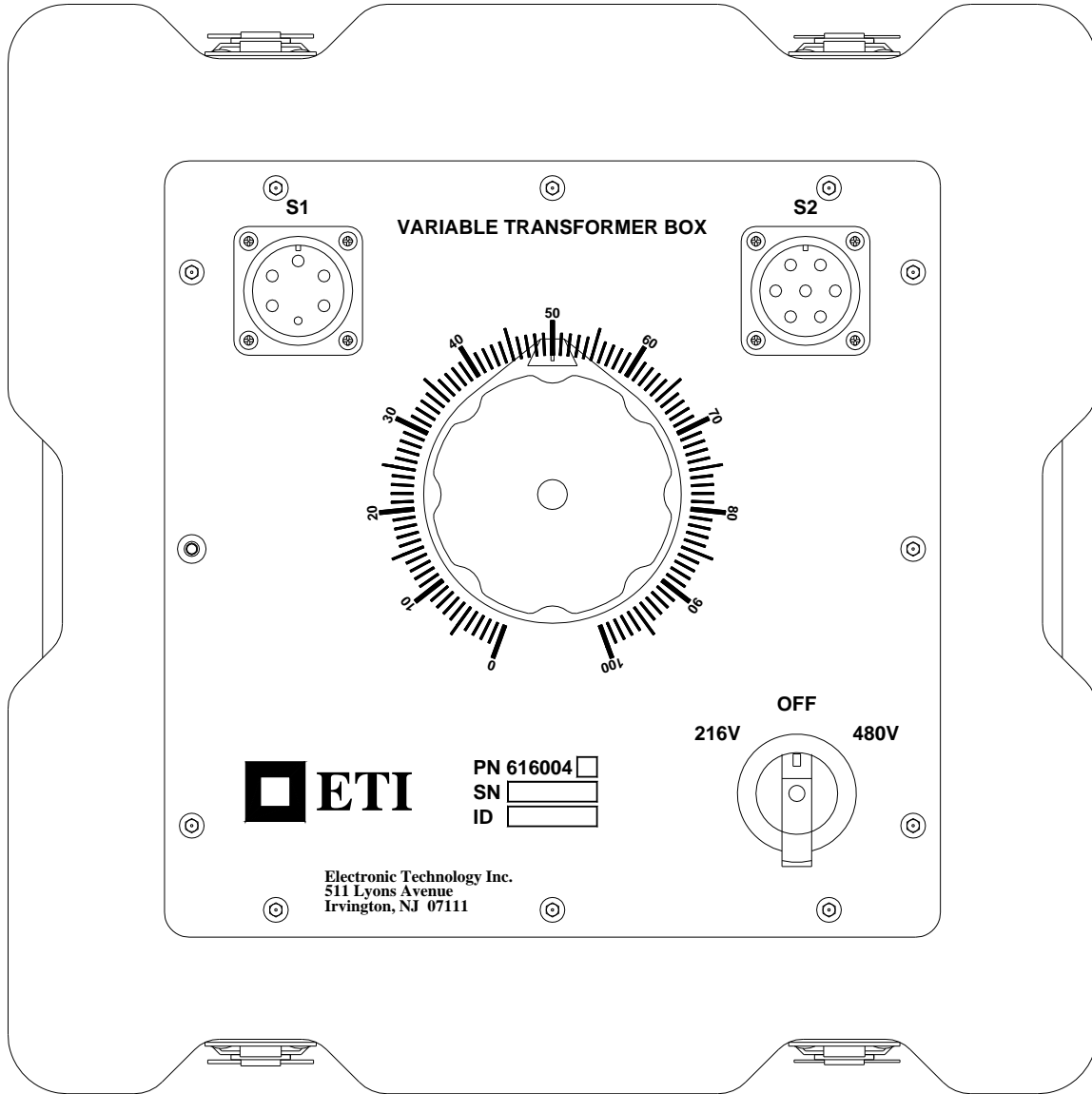

Figure 1: ETI Variable Transformer Box Faceplate

Chapter 2

Setup/Connections

I. PRELIMINARY OPERATING PROCEDURE

- A. De-energize and rack out the protector.
- B. Open both the Test Box and Variac Box. Remove all cables.
- C. Ensure all Test Box circuit breakers (**CP, T1, T2, T3, N1, N2, N3**) are in the *OFF* position.
- D. Ensure the **INPUT VOLTAGE SELECT SWITCH** is in the correct position for the given input voltage and the Variac adjust knob is turned fully counter-clockwise to 0.
- E. Find the input power cable that is packaged with the Test Box. This cable has four clip leads labeled T1, T2, T3, and NEUTRAL. Connect this to *SI* on the Variac Box.
- F. Connect the short interface cable that was packaged with the Variac Box between *S2* on the Variac Box and *SI* on the Test Box.
- G. Attach the remaining cable (the one with 7 clip leads, packaged with the Test Box) to the connector labeled *S3* on the Test Box. *SI* on the Variac Box is input power. *S3* on the Test Box provides a connection to the protector under test.
- H. Connect the Test Box and Variac Box to the protector and system power as shown in Figure 2
 1. Connect the three transformer leads of the Test Box to the transformer side of the network protector as follows: T1 (red) to phase 1, T2 (white) to phase 2, and T3 (blue) to phase 3.
 2. Connect the three network leads of the Test Box to the network side of the protector as follows: N1 (red) to phase 1, N2 (white) to phase 2, and N3 (blue) to phase 3.
 3. Connect the ground lead (black) from the *S3* connector to the frame of the protector.
 4. Connect the ground lead (black) from the *SI* connector of the Variac Box to a convenient system neutral.
 5. Connect the Green and Yellow ground cable to the provided stud on the top left corner of the Test Box's faceplate. Connect the ground clip (black boot) at the other end of this cable to a convenient system ground.
 6. Connect the Green and Yellow ground cable to the provided stud on the left side of the Variac Box's faceplate. Connect the ground clip (black boot) at the other end of this cable to a convenient system ground.

Note: The ground studs and all neutral connections are connected internally to the metal chassis of the Test Box and Variac Box. Do NOT connect the ground clips to a different ground potential than the neutral clips.
 7. Verify that the **INPUT VOLTAGE SELECT SWITCH** is in the correct position for the given input voltage and the Variac adjust knob is turned fully counter-clockwise to 0 before connecting it to a source of power.

Note: Failure to set this switch correctly can result in equipment damage and/or personal injury
 8. Connect the input power cables to a source of power as follows: A (red) to phase 1, B (white) to phase 2, and C (blue) to phase 3.
- I. Switch the control power (**CP**) breaker on, the Test Box should now start up.

- J. Switch on the three network and three transformer breakers.
- K. Put the Test Box into Voltage Display Mode
 - 1. Press **<B,4>**. The three phase to phase voltages should display on screen (at this point the voltages should be at or close to 0V). They are displayed as **T12** (Phase 1 to Phase 2), **T23** (Phase 2 to Phase 3), and **T13** (Phase 1 to Phase 3).
 - 2. If desired, press **NEXT (3)** to switch the display between Phase to Phase and Phase to Neutral input voltages.

II. DISCONNECTING INSTRUCTIONS

- A. Block the protector in the OPEN position using the handle.
- B. Switch the three network and the three transformer breakers to the **OFF** position.
- C. Switch the **CP** breaker to the **OFF** position.
- D. Move the **INPUT VOLTAGE SELECT SWITCH** to the **OFF** position.
- E. Remove the A, B, and C leads from the source of power.
- F. Remove the three network leads (N1, N2, N3) and the three transformer leads (T1, T2, T3) from the network protector.
- G. Remove the ground and neutral leads.
- H. Disconnect the **S1** and **S3** connectors from the Test Box.
- I. Disconnect the **S1** and **S2** connectors from the Variac Box.
- J. Pack all the leads neatly into their appropriate covers.
- K. If the relays and the network protector operated satisfactorily put the network protector back on the system in the prescribed manner and leave network protector in the AUTO position unless otherwise directed.

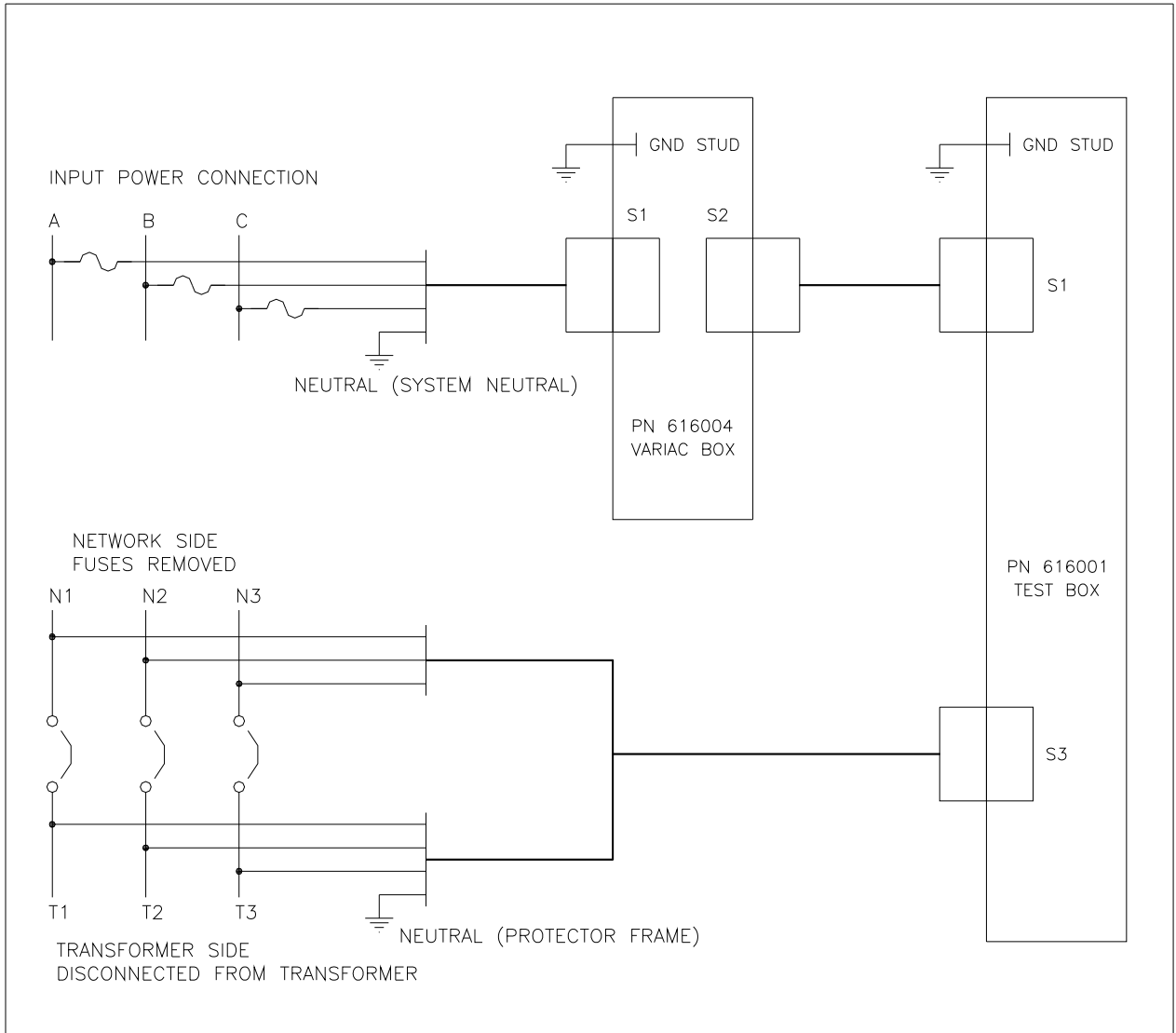

Figure 2: Variac and Test Box Connections

Chapter 3

Sample Operating Procedures

(Individual Utility Procedures May Vary)

I. TRIPPING VOLTAGE RANGE

- A. If you have not already done so, connect the Variac and Test Boxes as described in Chapter 2 Section I (Preliminary Operating Procedure).
- B. Manually close the network protector.
- C. Adjust voltage to 7.5% (10V for 125V, 21V for 277V).
- D. Jumper the Arm and Trip contacts on the network protector relay socket (1 and 2 on WH, 3 and 1 on GE -- See Figures 3 and 4). The protector should trip.
- E. Repeat test for 100% voltage (125V for 125V, 277V for 277V).

II. CLOSING RELAY RANGE

- A. If you have not already done so, connect the Variac and Test Boxes as described in Chapter 2 Section I (Preliminary Operating Procedure).
- B. Manually open the network protector.
- C. Adjust voltage to 73% (91V for 125V, 202V for 277V).
- D. Jumper the Arm and Close contacts on the network protector relay socket (1 and 3 on WH, 3 and 2 on GE -- See Figures 3 and 4). The mechanism should **NOT** pick up.
- E. Adjust voltage to 80% (100V for 125V, 222V for 277V).
- F. Jumper the Arm and Close contacts on the network protector relay socket (1 and 3 on WH, 3 and 2 on GE -- See Figures 3 and 4). The protector should close.

III. LOW VOLTAGE CLOSE ON MOTOR

- A. If you have not already done so, connect the Variac and Test Boxes as described in Chapter 2 Section I (Preliminary Operating Procedure).
- B. Manually open the network protector.
- C. Adjust voltage to 73% (91V for 125V, 202V for 277V).
- D. Manually activate the motor closing relay. The protector should close.

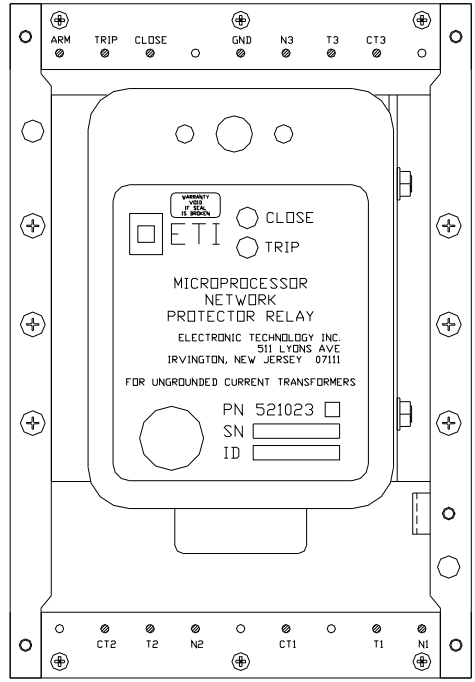

Figure 3: WH Relay

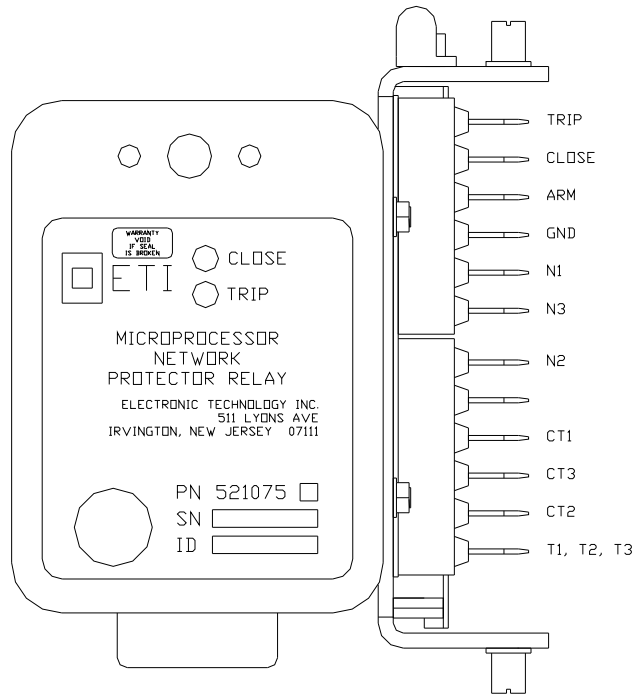

Figure 4: GE Relay

Appendix A

Specification Sheet

1. **INPUT VOLTAGE:** 125/216 VAC $\pm 10\%$ or 277/480 VAC $\pm 10\%$, 60Hz, 3 Phase Wye
2. **OUTPUT VOLTAGE:** Adjustable from 0 to 300 VAC (line to neutral) on 216V input setting. Adjustable from 0 to 277 VAC (line to neutral) on 480V input setting.
3. **OUTPUT RATING:** 7.3 KVA
4. **ENVIRONMENTAL:** The Variac Box is protected from damage caused by rain or high humidity. The Variac Box is not submersible.
5. **WEIGHT:** Approximately 60 lbs including cables
6. **SIZE:** 14 x 14 x 19 inches.